



US005914605A

United States Patent [19]

[11] Patent Number: **5,914,605**

Bertness

[45] Date of Patent: ***Jun. 22, 1999**

[54] **ELECTRONIC BATTERY TESTER**

4,881,038	11/1989	Champlin	324/426
4,912,416	3/1990	Champlin	324/430
5,140,269	8/1992	Champlin	324/433
5,343,380	8/1994	Champlin	363/46
5,572,136	11/1996	Champlin	324/426
5,574,355	11/1996	McShane et al.	320/161
5,585,728	12/1996	Champlin	324/427
5,598,098	1/1997	Champlin	324/430

[75] Inventor: **Kevin I. Bertness**, Batavia, Ill.

[73] Assignee: **Midtronics, Inc.**, Burr Ridge, Ill.

[21] Appl. No.: **09/006,226**

[22] Filed: **Jan. 12, 1998**

Primary Examiner—Diep N. Do
Attorney, Agent, or Firm—Hallie A. Finucane, Esq.;
Westman, Champlin & Kelly, P.A.

Related U.S. Application Data

[60] Provisional application No. 60/035,312, Jan. 13, 1997.

[51] **Int. Cl.**⁶ **G01N 27/416**; H01M 10/48

[52] **U.S. Cl.** **324/430**; 324/427; 320/161

[58] **Field of Search** 324/427, 430,
324/433; 340/636; 320/151, 156, 161

[57] ABSTRACT

A microprocessor couples to a voltage sensor through an analog to digital converter. The voltage sensor is adapted to be coupled across terminals of a battery. A small current source is also provided and adapted to be coupled across the terminal to the battery. The current source is momentarily applied to the battery and the resulting change in voltage is monitored using the microprocessor. The microprocessor calculates battery conductance based upon the magnitude of the differential current and the change in voltage and thereby determines the condition of the battery.

[56] References Cited

U.S. PATENT DOCUMENTS

3,873,911	3/1975	Champlin	324/430
3,909,708	9/1975	Champlin	324/431
4,816,768	3/1989	Champlin	324/428
4,825,170	4/1989	Champlin	324/436

11 Claims, 4 Drawing Sheets

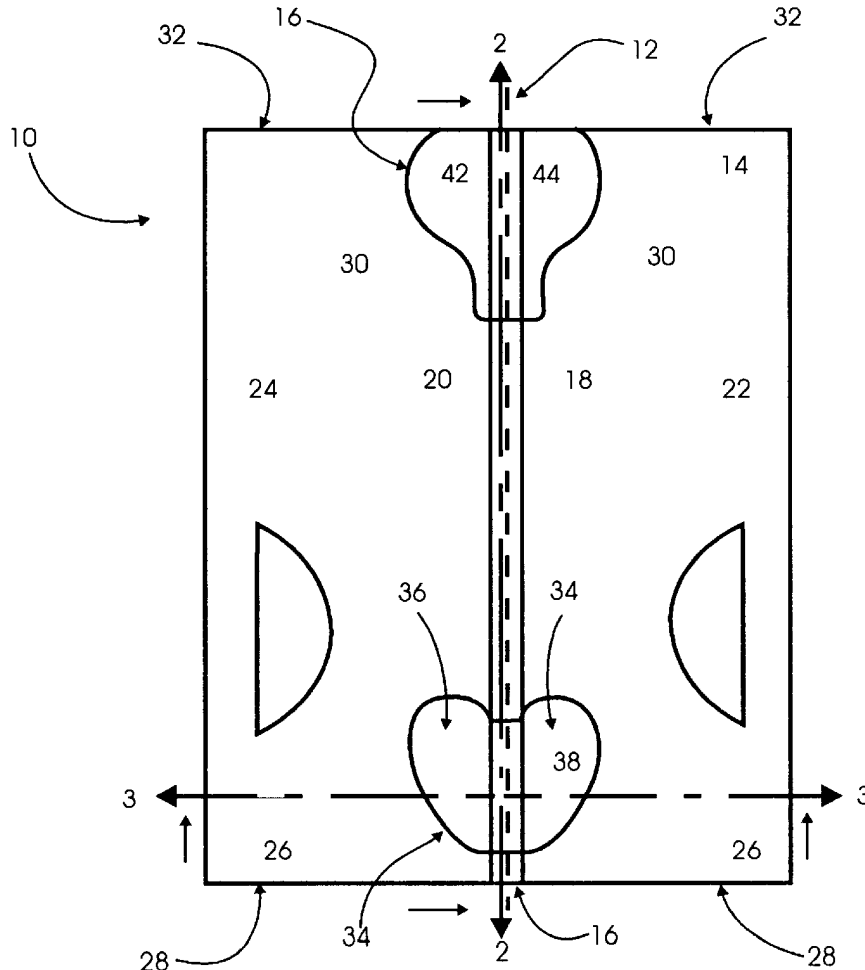

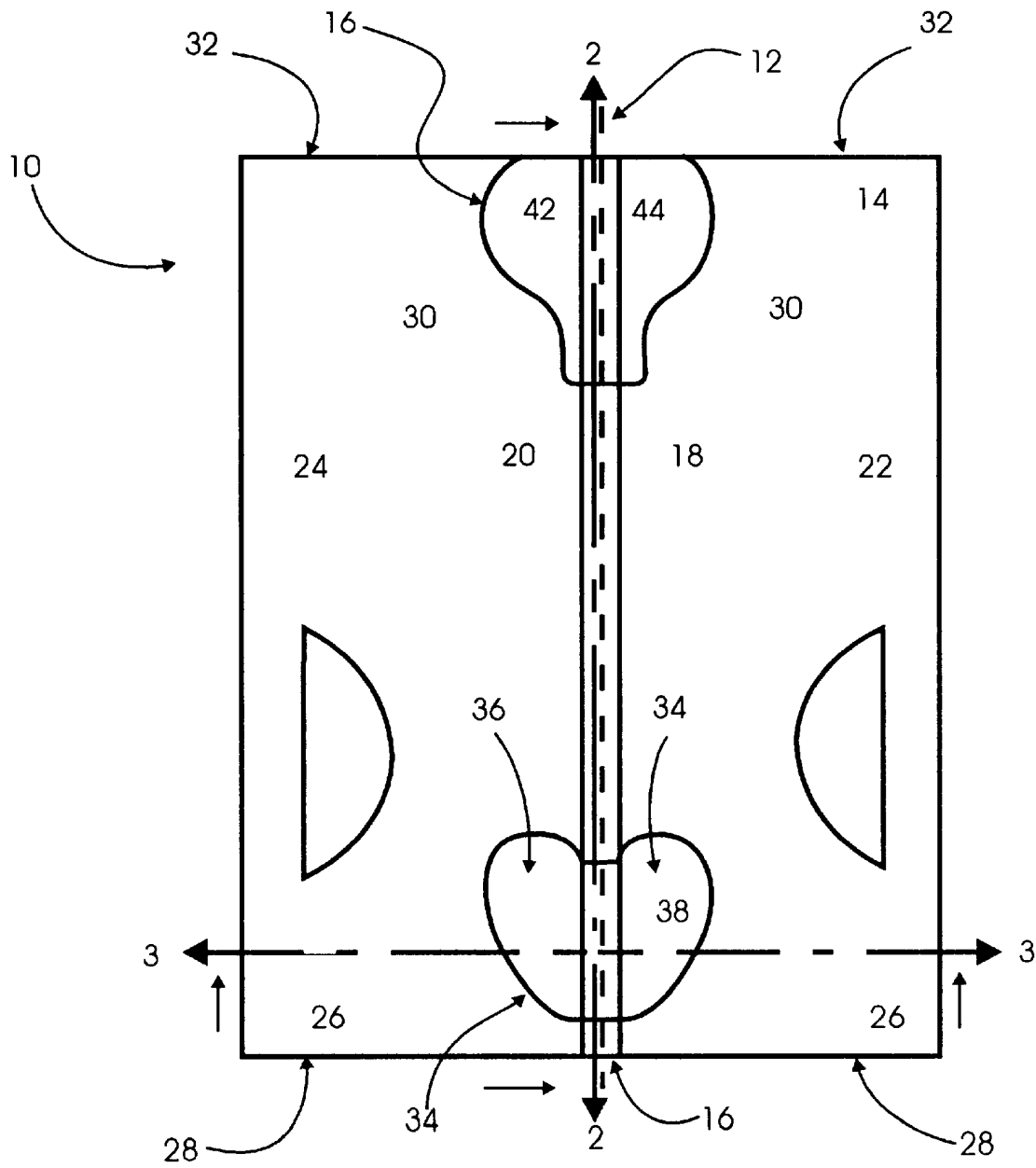

FIG. 1

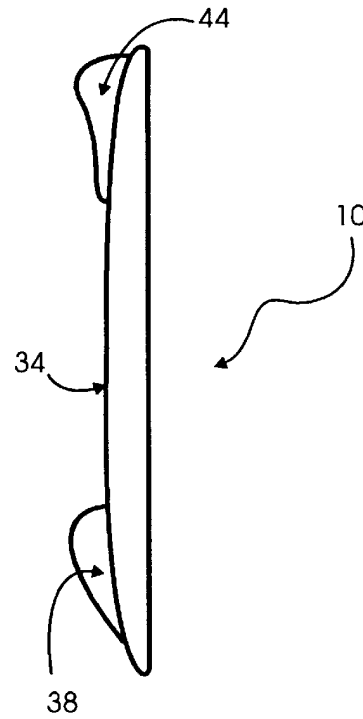

FIG. 2

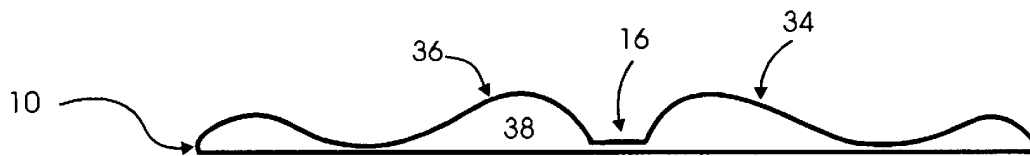

FIG. 3

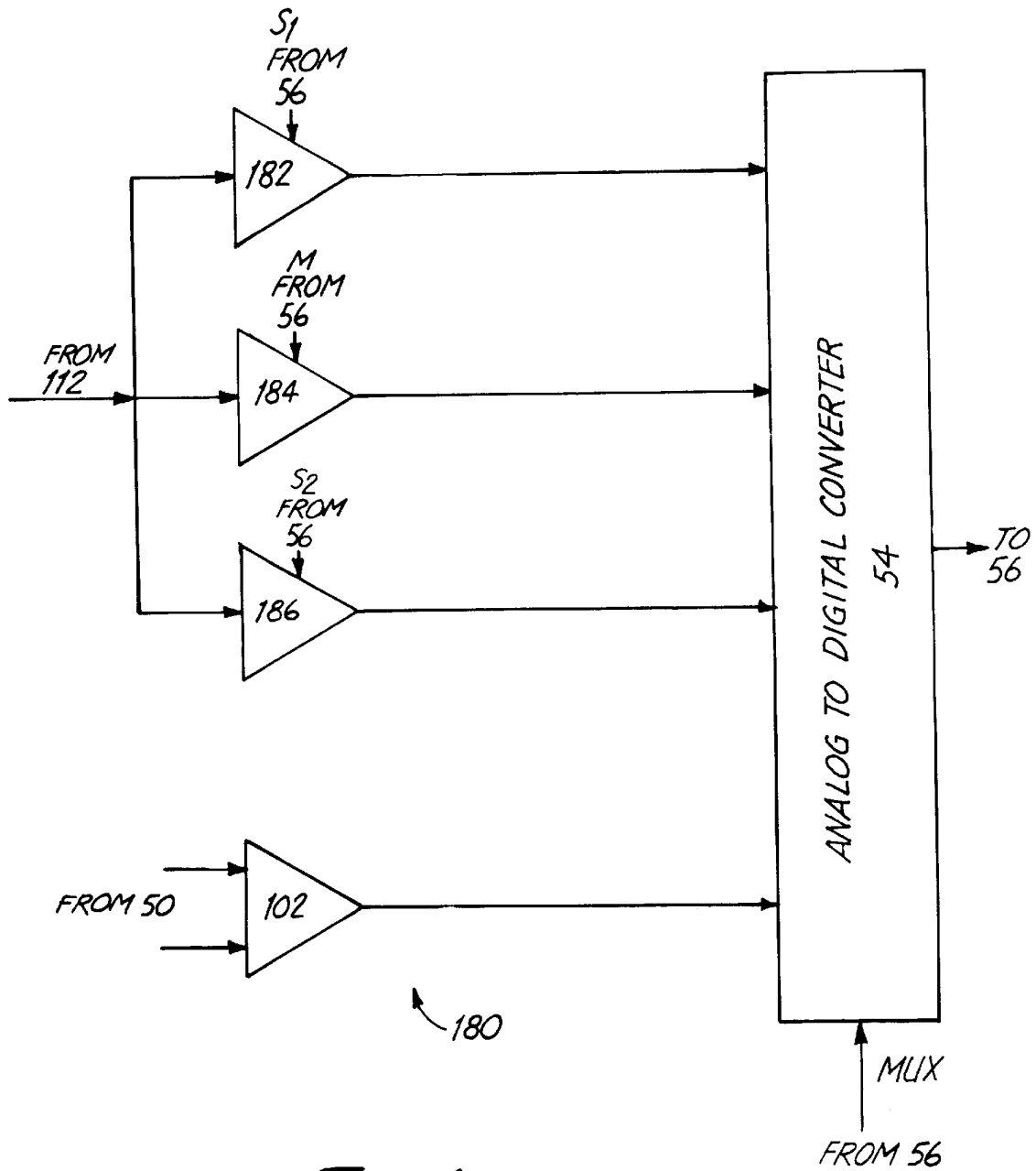

Fig. 4

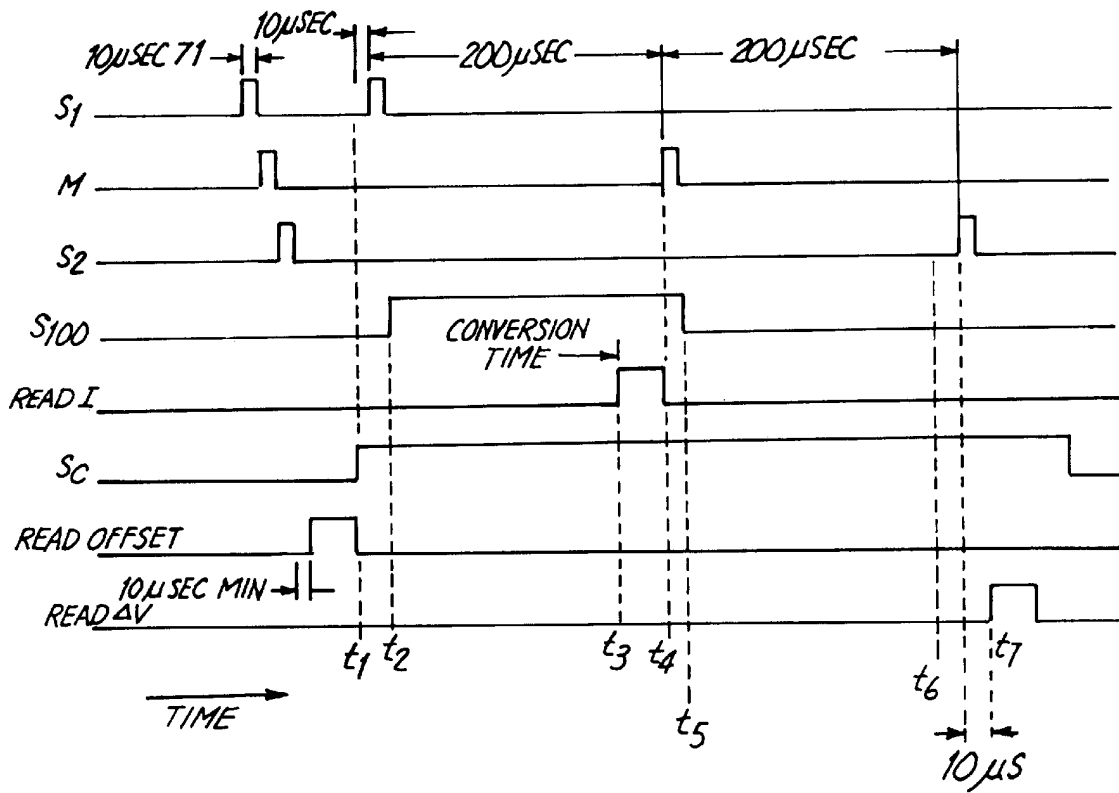

Fig. 5

ELECTRONIC BATTERY TESTER

BACKGROUND OF THE INVENTION

The present invention claims priority to Provisional Application Ser. No. 60/035,312, filed Jan. 13, 1997 and entitled "ELECTROINC BATTERY TESTER."

The present invention relates to battery testing devices. The present invention is particularly applicable to a technique for measuring conductance of a battery in which a small resistive load is momentarily placed across the battery and the change in voltage is monitored.

Chemical storage batteries, such as lead acid batteries used in automobiles, have existed for many years. In order to make optimum use of such a battery, it is very desirable to test the battery to determine various battery parameters such as state of charge, battery capacity, state of health, the existence of battery defects.

Various techniques have been used to measure battery parameters. For example, hygrometers have been used to measure the specific gravity of a battery and simple voltage measurements have been used to monitor the voltage of the battery. One battery testing technique which has been popular for many years is known as a load test in which a battery is heavily loaded over a period of time and the decay in the battery output is monitored. However, such a test is time consuming and leaves the battery in a relatively discharged condition. Further, such a tester must be made relatively large if it is to be used with large batteries.

A much more elegant technique has been pioneered by Midtronics, Inc. of Burr Ridge, Ill. and Dr. Keith S. Champlin in which battery parameters are determined based upon a measurement of the battery's conductance. This work is set forth in, for example, the following patents issued to Champlin: U.S. Pat. No. 3,873,911; U.S. Pat. No. 3,909,708; U.S. Pat. No. 4,816,768; U.S. Pat. No. 4,825,170; U.S. Pat. No. 4,881,038; U.S. Pat. No. 4,912,416; U.S. Pat. No. 5,140,269; U.S. Pat. No. 5,343,380; U.S. Pat. No. 5,572,136; and U.S. Pat. No. 5,585,728 and the following patents assigned to Midtronics, Inc., U.S. Pat. No. 5,574,355 and U.S. Pat. No. 5,592,093.

However, there is an ongoing need to refine battery testing techniques, improve their accuracy and improve the types of applications in which they may be successfully employed.

SUMMARY OF THE INVENTION

A microprocessor couples to a voltage sensor through an analog to digital converter. The voltage sensor is adapted to be coupled across terminals of a battery. A small current source is also provided and adapted to be coupled across the terminal to the battery. The current source is momentarily switched on to provide a current (which may be a current drop) through the battery and the resulting change in voltage is monitored using the microprocessor. The microprocessor calculates battery conductance based upon the magnitude of the current and the change in voltage. These techniques are employed to overcome noise from noise sources which may be coupled to the battery during the battery test.

BRIEF DESCRIPTION OF THE DRAWINGS

FIG. 1 is a simplified electrical schematic diagram of a battery tester in accordance with the present invention.

FIG. 2 is a simplified electrical schematic diagram of a portion of sense circuitry shown in FIG. 1.

FIG. 3 is a simplified electrical schematic diagram of a portion of sense circuitry shown in FIG. 1.

FIG. 4 is a simplified electrical schematic diagram of a portion of sense circuitry shown in FIG. 1.

FIG. 5 is a timing diagram showing various signals during operation of the circuitry of FIGS. 1 through 4.

DETAILED DESCRIPTION OF THE PREFERRED EMBODIEMENTS

It has been discovered that measuring battery conductance of a storage battery connected to noise sources is a particularly difficult problem. Such noise sources include the charging system and various electronics in an automobile, for example, or other types of charging systems and electronics which may be connected to storage batteries. These noise sources interfere with the battery test. The present invention includes a number of techniques to overcome the limitations imposed by such noise.

FIG. 1 is simplified block diagram of a battery tester 10 in accordance with the present invention coupled to an electrical system 4. Electrical system 4 is an model which includes a charge signal noise source 6 and a load signal noise source 8. These sources could be, for example, the load and charger of an automobile or a uninterruptable power system (UPS).

Battery tester 10 determines the conductance of battery 12 in accordance with the present invention and includes test circuitry 16. Circuitry 16 includes a current source 50 (which comprises, for example, a resistance R_L), sensor circuitry 52, analog to digital converter 54 and microprocessor 56. In one preferred embodiment, microprocessor 56 comprises a Motorola MC 68HC705C8P. Sensor circuitry 52 is capacitively coupled to battery 12 through capacitors C1 and C2 and has its outputs connected to a multiplexed or input of analog to digital converter 54. A/D converter 54 is also connected to microprocessor 56 which connects to system clock 58, memory 60, output 62 and input 66. Output 62 comprises, for example, a display and input 66 may comprise a keyboard, RF link, bar code reader, etc.

In operation, current source 50 is controlled by microprocessor 56 using switch 100 which may comprise, for example, a FET. Current source 50 provides a current I in the direction shown by the arrow in FIG. 1. In one embodiment, this is a square wave or a pulse. The voltage sense circuitry 52 connects to terminals 22 and 24 of battery 12 to capacitors C1 and C2, respectively, and provides an output related to the voltage difference between the terminals. Sense circuitry 52 preferably has a high input impedance. Note that circuitry 16 is connected to battery 12 through a four point connection technique known as a Kelvin connection. Because very little current flows through circuitry 52, the voltage drop through its connections to battery 12 is relatively insignificant. The output of circuitry 52 is converted to a digital format and provided to microprocessor 56. Microprocessor 56 operates at a frequency determined by system clock 58 and in accordance with program instructions stored in memory 60.

In general, microprocessor 56 determines the conductance of battery 12 by actuating switch 100 to apply a current pulse with current source 50. The microprocessor determines the change in battery voltage due to the current pulse using circuitry 52 and analog to digital converter 54. The value of current I generated by current source 50 is measured by measuring the voltage drop across resistance R_L using amplifier 102. Microprocessor 56 calculates the conductance of battery 12 as follows:

$$\text{Conductance} = G = \frac{\Delta I}{\Delta V} \quad \text{Equation 1}$$

where ΔI is the change in current flowing through battery 12 due to current source 50, and ΔV is the change in battery voltage due to applied current ΔI . The relative conductance of battery 12, as discussed with respect to FIG. 2, is calculated using the equation:

$$\text{Relative Conductance (\%)} = \frac{G_{\text{measured}}}{G_{\text{reference}}} \times 100 \quad \text{Equation 2}$$

where G_{measured} is the battery conductance in accordance with Equation 1 and $G_{\text{reference}}$ is a reference conductance value received through input 66 and stored in memory 60. Generally, this reference conductance is determined based upon the type and characteristics of battery 12. Microprocessor 56 can also operate using impedance measurements by inverting Equations 1 and 2. The relative conductance measurement may then be output using data output 62 which may comprise, for example, a display, meter, data link, etc.

The measurement of conductance in a noisy environment using circuitry 16 may be accomplished by maintaining a relatively short connection of resistance R_L across battery 12 and measuring the resultant small voltage drop. The DC voltage drop across the battery is a minimum of 2 volts and the absolute voltage drop across the battery may be any value. Sense circuitry 52 preferably has a relatively large gain which is saturated if circuitry 52 is directly coupled to battery 12. Therefore, capacitors C1 and C2 are provided to capacitively coupled circuitry 52 to battery 12.

FIG. 2 is a simplified electrical schematic diagram 110 of a portion of sense circuitry 52 shown in FIG. 1. Circuitry 110 includes differential amplifier 112 having an inverting input connected to terminal 22 of battery 12 through capacitor C1 and resistors 114 and 116 having values of 10 K Ω and 40.2 K Ω . The non-inverting input of amplifier 112 connects to terminal 24 through capacitor C2 and resistors 118 and 120 having values of 10 K Ω and 40.2 K Ω , respectively. The non-inverting input of amplifier 112 connects to electrical ground through resistor 122 having a value of 1 M Ω feedback is provided from the output of amplifier 112 through resistor 124 having a value of 1 M Ω . Capacitors C1 and C2 have values of 0.1 μ F and are ground through resistors 126 and 128 which have a value of 1 M Ω . Low impedance path resistors 130 and 132 have values of 1 K Ω and are selectively coupled to capacitors C1 and C2 through switches 134 and 136, respectively. Switches 134 and 136 may comprise, for example, FETs which are controlled by microprocessor 56.

In order to make accurate AC transient measurements, it is necessary that the bias voltage across the input coupling capacitors C1 and C2 remains relatively constant. This is facilitated by using relatively large capacitor values for C1 and C2 and employing coupled to a high input impedance circuit for circuit 52. However, a significant drawback to the high impedance is that a relatively long time is required for the amplifier to stabilize to a quiescent operating point when the tester is first started or relocated to a different battery. Resistors 130 and 132 provide a relatively low impedance path to electrical ground when switches 134 and 136, respectively, are actuated by microprocessor 56. Preferably, the switches 134 and 136 are actuated just prior to measurements to thereby quickly establish the operating point of the system. A further advantage of application of the low

impedance paths during a non-test interval is that they allow quiescent operating points that are elevated (or depressed) due to system noise, thereby placing no practical limit on the amount of low frequency noise that can be rejected.

Another source of inaccuracy due to noise in the system is the variability in the voltage bias at the inputs of capacitors C1 and C2 which arises due to the inductive coupling of the pulse generated by source 50 to the voltage sense leads which couple circuitry 52 to battery 12. This causes relatively large voltage spikes in the connection leads which could damage the sense circuitry leading to inaccurate readings. Diode pairs 152 and 154 are provided as input protection devices to eliminate this and exacerbate this problem by tying one side of capacitor C1 and C2 to a power supply rail through an extremely low impedance path (the forward diode direction). In order to overcome this problem, switches 160 and 162 are provided which selectively as shown in FIG. 3 couple capacitors C1 and C2 to resistors 114 and 118, respectively. Switches 160 and 162 may comprise, for example, FETs which are controlled by microprocessor 56. Microprocessor 56 controls switches 160 and 162 to provide an open circuit during the occurrence of any voltage that exceeds the value of the power supply rails. Leakage is only about 1 nanoamp. This allows capacitors C1 and C2 to “free wheel” during a voltage spike with no resultant in charging.

Another aspect of the invention includes the determination of the quiescent operating point of the battery voltage during application of the current pulse from source 50. It is desirable to exactly determine this applying point. However, this is not possible because the current pulse has changed the operating point by an amount inversely proportional to the conductance. Additionally, the quiescent point varies according to the AC or DC noise which is present on the system. The present invention estimates the quiescent operating point during the current pulse by taking samples before and after the current pulse and averaging the difference. FIG. 4 is a simplified electrical schematic diagram of circuitry 180 which is part of circuitry 52 shown in FIG. 1. Circuitry 180 includes circuitry 52 as shown in FIG. 1. Circuitry 180 includes three sample and hold elements 182, 184 and 186 which couples to amplifier 112 shown in FIGS. 2 and 3. Additionally, sample and hold circuits 182 through 186 receive control signals S_1 , M, and S_2 from microprocessor 56. The output from amplifier 102 is also shown connected to analog to digital converter 54. Analog to digital converter 54 includes a multiplex input which is controlled by MUX line from microprocessor 56 to select one of the inputs from amplifier 102 or sample and hold circuits 182 through 186.

FIG. 5 is a timing diagram showing operation of the circuitry in FIGS. 1 through 4. Signal S_1 is applied by microprocessor 56 to sample and hold circuit 182, signal M is applied to sample and hold circuit 184 and signal S_2 is applied to circuit 186 shown in FIG. 4. Signal S_{100} controls switch 100 shown in FIG. 1. The READ I signal couples analog to digital converter 54 to amplifier 102 to thereby read the voltage drop across resistance R_L . The S_C signal controls switches 160 and 162 shown in FIG. 3. The READ OFFSET signal controls analog to digital converter 54 to initially read offsets from sample and hold 182 through 186. The read ΔV signal controls reading of the sample and hold circuits 182 through 186 with the A/D 54 following a measurement cycle. During operation, the values of the three sample and holds are initially latched using the first pulse shown in signals S_1 , M, and S_2 . During this initial reading, switches 160 and 162 are open such that the voltages V_{S1}^0 ,

V_M^0 , V_{S2}^0 present on these latches constitute offset values. These offsets are stored in memory **60** and subtracted from subsequent voltage measurements by microprocessor **56** to thereby reduce errors. At time t_1 switches **160** and **162** are closed by signal S_C and sample and hold circuit **182** is again latched using signal S_1 to store the first measured voltage V_1 . At time t_2 , current I is applied to battery **12** by closing switch **100** with signal S_{100} . After about $150 \mu S$, the READ I is used to control A/D converter **54** to read the voltage output from amplifier **102**. At time t_4 , sample and hold circuit **184** is triggered by signal M to store the current voltage V_M across battery **12**. At time t_5 , the current I is removed from battery **12** and after a settling period of approximately $200 \mu S$, sample and hold circuit **186** is triggered by signal S_2 to store V_2 . At time t_7 , the A/D converter **54** to convert the voltage difference of the sample stored in circuits **182** and **186**. In various embodiments, this difference may be determined using analog subtraction techniques or digital subtraction using microprocessor **56**. The change in voltage of the battery due to applied current I is then calculated using the formula:

$$\Delta V = \frac{[(V_1 - V^0_1) + (V_2 - V^0_2)]}{2} - (V_M - V^0_M) \quad \text{Equation 3}$$

G is then determined using the formula:

$$G = \frac{(V_M - V^0_M) / R_L}{\Delta V} \quad \text{Equation 4}$$

As can be seen in Equations 3 and 4, the offset values V^0_1 , V^0_2 and V^0_M are subtracted from the measured values to thereby remove any systems offsets.

Another source of errors in measurement in noisy environments is due to lumped sum non-linearities in the circuit. In general, the equation for conductance is $G=I/V$, where G represents the conductance in mhos, I represents the current differential in amps and V represents the voltage differential in volts. Non-linearities in circuit **16** may cause a small offset component in the measured value of V . This offset may be determined during manufacture or during later calibration of circuitry **16** by forcing the input to circuitry **16** to 0 volts and measuring the resultant voltage. This voltage value (X) is stored in memory **60** and used to modify the equation for conductance by subtracting the offset from all measurements $G=I/(V-X)$.

In another aspect of the invention, non-linearities in circuitry **16** are compensated or "linearized" using a second order polynomial equation. Such non-linearities may be due to many factors including cabling, PCB layout, magnetic effects, etc. The polynomial is determined by measuring a plurality of calibrated standards using an uncalibrated tester **16** and the resultant data is fit to a curve using curve fitting techniques. For example, Table 1 is a series of measurements of seven different test cells having known voltage and conductance values by a battery tester prior to such calibration:

TABLE 1

CELL	VOLTS	MEASURED MHOS	ACTUAL MHOS	% ERROR
1	4.40	648	800.73	+23.57
2	4.40	1080	1333.33	+23.46
3	4.42	1638	2000.16	+22.11

TABLE 1-continued

CELL	VOLTS	MEASURED MHOS	ACTUAL MHOS	% ERROR
4	4.42	2194	2665.10	+21.47
5	4.42	3341	4000.00	+19.72
6	4.44	5107	6001.68	+17.52
7	4.44	6968	7995.52	+14.75

Using a least squares curve fitting technique, a quadratic equation of the form:

$$G_{actual} = 1,34894810^{-1} + 1.245607G_{measured} - 1.40414210^{-5}G_{measured}^2 \quad \text{Equation 5}$$

Equation 5 can be used to calibrate the measured value of mhos. The three constants in Equation 5 are stored in memory **60** for use by microprocessor **56**.

Another technique of the present invention to overcome problems associated with noise includes employing statistical algorithms in microprocessor **56**. Amplifier **12** is instantly able to take readings at any point, regardless of prior disturbance of the quiescent operating point due to noise, in other words, quiescent disturbances do not require a long "settling period" following the disturbance before another reading can be taken. If the noise signal remains linear and continuous, readings can be taken during the noise signal itself. However, difficulties arise in very high noise environments, where the noise is of large value, and not linear or continuous (for example, UPS switching currents). This "impulse" noise present during the measurement period causes incorrect values to be recorded for that sample, even though they do not affect the ability of the amplifier to take another sample immediately following it. Noise pulses of particular concern are high amplitude, short duration, low frequency (360 Hz, for example) spikes. Since the measurement period is short (200 microseconds), circuit **16** can take a large number of measurements in a short period of time. In doing so, there is a high incidence of samples containing the correct value of conductance, and a lower number of samples containing corrupted data. Microprocessor **56** determines the median or mean values over a large number of samples and is thereby able to intelligently decode the correct value from the scattered measured data.

Although the present invention has been described with reference to preferred embodiments, workers skilled in the art will recognize that changes may be made in form and detail without departing from the spirit and scope of the invention.

What is claimed is:

1. An apparatus for measuring conductance of a battery, comprising:
 - a positive sense electrical connection adapted to couple to a positive terminal of the battery;
 - a negative sense electrical connection adapted to couple to a negative terminal of the battery;
 - a positive current electrical connection adapted to couple to the positive terminal of the battery;
 - a negative current electrical connection adapted to couple to the negative terminal of the battery;
 - a current source;
 - a current switch selectively coupling the current source between the positive current electrical connection and the negative current electrical connection;

7

- a first capacitor connected in series with the positive sense electrical connection;
 - a second capacitor connected in series with the negative sense electrical connection;
 - a differential amplifier having a first input, a second input and a differential output;
 - a first switch selectively coupling the first input of the differential amplifier to the first capacitor;
 - a second switch selectively coupling the second input of the differential amplifier to the second capacitor; and
 - control circuitry coupled to the current switch, the first switch and the second switch selectively supplying the current source to the battery by actuating the current switch and maintaining at least a momentary disconnection between the battery and the amplifier by closing the first and second switches;
- the control circuitry responsively determining battery conductance as a function of differential current flow through the battery due to the applied and differential voltage drop across the battery based upon the differential output.
2. The apparatus of claim 1 wherein the current source comprises a resistance.
 3. The apparatus of claim 1 wherein the control circuitry provides an output related to relative battery conductance as a function of the battery conductance and a reference battery conductance.
 4. The apparatus of claim 1 including:
 - the third switch selectively coupling the first input of the differential amplifier to a reference; and

8

- wherein the control circuitry actuates the third switch to momentarily couple the first input of the differential amplifier to the reference prior to determining battery conductance.
5. The apparatus of claim 1 wherein the control circuitry determines battery voltage prior to measuring current flow (V_1), during a measurement of current flow (V_M) and subsequent to measuring current flow and calculates change in voltage (ΔV) as a function of V_1 , V_M and V_2 .
 6. The apparatus of claim 5 including a first sample and hold circuit for sampling V_1 , a second sample and hold circuit for sampling V_M and a third sample and hold circuit for sampling V_2 .
 7. The apparatus of claim 1 wherein the control circuitry subtracts an offset voltage in determining differential voltage drop.
 8. The apparatus of claim 7 wherein the offset voltage is measured prior to determining battery conductance.
 9. The apparatus of claim 1 including a memory and wherein the control circuitry compensates battery conductance as a function of an equation stored in the memory.
 10. The apparatus of claim 9 wherein the equation comprises a polynomial of the form:

$$G_{compensated} = a + b G_{measured} + c G_{measured}^2$$
 Where a, b and c are stored in the memory.
 11. The apparatus of claim 1 wherein the control circuitry determines battery conductance as a statistical function of a plurality of differential current flow measurements and differential voltage measurements.

* * * * *